

QUICK START INSTALLATION INSTRUCTIONS



SPIDER® PLUS
INTERLOCKING FIBER TECHNOLOGY

SMART, CLEAN & VERSATILE

The premium blow-in insulation solution

PREPARATION

Spider Plus Coverage Chart

Wall Type	R-Value	RSI	Density (lbs/ft³)	ft²/bag	m²/bag	bags/1000ft²	bags/100m²
2x4	14	2.5	1.5	68.6	6.4	14.6	15.7
	15	2.6	1.8	57.1	5.3	17.5	18.8
2x6	22 US / 23 CAN	3.9 US / 4.1 CAN	1.5	43.6	4.1	22.9	24.7
	23 US / 24 CAN	4.1 US / 4.2 CAN	1.8	36.4	3.4	27.5	29.2

Properly secure equipment in truck

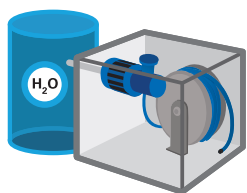

Fluid Delivery System
(with water tank)

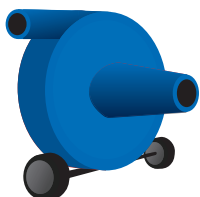

Vacuum



Spider® Plus



Fuel

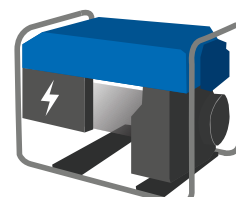

Generator

Additional Equipment & Supplies

Scrubber	Water Bucket	Batt Material	Extension Cords
Spray Nozzle (HDN)	Foam Sealant	Rolls of Poly	Tool Box
Extra Spray Tips	Netting	Duct Tape	Hose Clamps
Vacuum Hose	Stapler & Staples	Scaffold & Ladder	Brooms
Extra Lighting	Orifice Gauge	Fish Scale	Weighing Bags

JOBSITE PREPARATION

- Hook-up Hoses
- Remove Nails
- Seal Penetrations
- Net Open Walls
- Mask Electric Boxes and HVAC Vents
- Chink or Foam Cracks
- Sweep Floor
(To avoid vacuuming trash, dirt or construction debris)

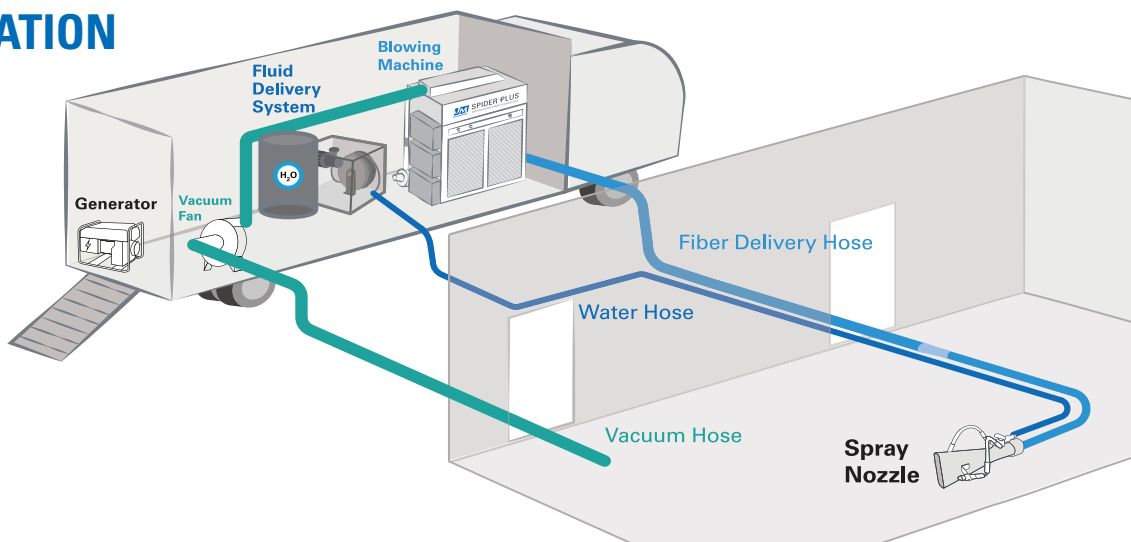

EQUIPMENT SETUP NOTES:

1. Set up blowing machine to achieve 1.5 to 1.6 psi **orifice** pressure (at the end of the blow hose) with no material flowing (2.0 to 2.5 psi for overhead application).
2. Set up material feed rate to achieve approximately 20 lbs/min of Spider Plus.
3. Make sure water spray tips are clean and undamaged.
4. Set up water pump to run at 1000 psi at the gauge in the fluid delivery system.
5. Check water flow rate at nozzles to ensure approximately 2.2 lbs/min and a wide mist spray pattern (65° wide mist).
6. Record setup parameters to speed up future setup process.

WALLS

Spraying:

Using a high density nozzle (HDN), spray at a distance of 15-30 inches (closer for higher density, further for lower density).

When turning spray nozzle on and off, the water spray should be the first on and the last off. If needed, move nozzle closer at the top and bottom of cavity to avoid low density in these areas.

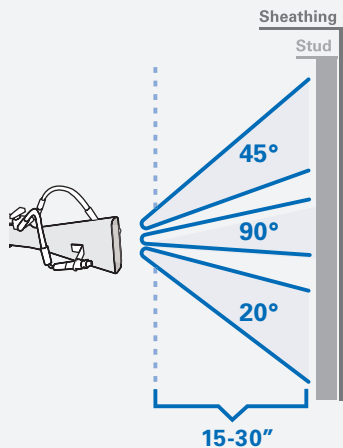

Scrubbing:

Scrub the face of the cavities to remove excess material. Vacuum flyoff and excess material into refeed system. Maintain a sufficient quantity of new material in the hopper to avoid spraying with only refeed.

A 3-person crew is recommended to keep up with spraying, scrubbing and vacuuming to ensure minimal fluctuation in refeed rate.



OVERHEAD

Establish a foundation in the end of a cavity, then fill the cavity in layers

1 Water Pre-spray*

*Not necessary for some applications

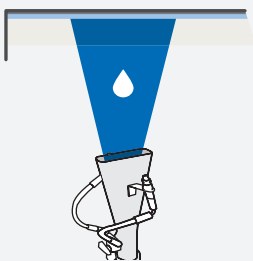

2 End of Cavity

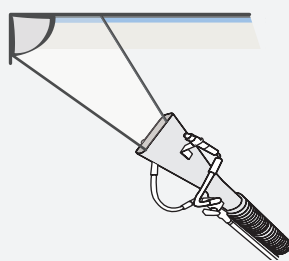

3 Base Coat

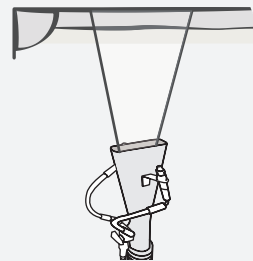

4 Fill Cavity

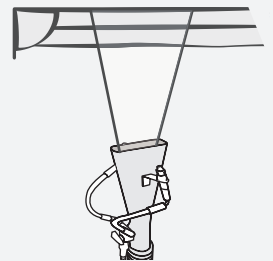

JOBSITE CLEANUP:

- Remove masking
- Clean the details (material is easily removed by hand or broom)
- Sweep the floor (don't vacuum dirt & debris with refeed system)
- Properly secure equipment in truck
- Store fluid delivery system in a location that will avoid freezing